

DOCUMENT RESUME

ED 322 496

CS 212 395

AUTHOR Stanley, Linda  
 TITLE The Best of Both Discourse Worlds: A Two-Tiered Writing Program for the Community College Technology Curriculum.  
 PUB DATE Mar 90  
 NOTE 27p.; Paper presented at the Annual Meeting of the Conference on College Composition and Communication (41st, Chicago, IL, March 22-24, 1990).  
 PUB TYPE Speeches/Conference Papers (150) -- Reports - Descriptive (141)

EDRS PRICE MF01 Plus Postage. PC Not Available from EDRS.  
 DESCRIPTORS \*Community Colleges; Interdisciplinary Approach; \*Technical Writing; Two Year Colleges; \*Writing Across the Curriculum; Writing Assignments; Writing Improvement; \*Writing Laboratories; Writing Strategies

IDENTIFIERS City University of New York Queensborough Comm C; English Teachers

ABSTRACT

A writing across the curriculum program at Queensborough Community College in New York began its work on campus as Writing and Reading in the Technologies (WRIT) and chose to work with the Electrical and Computer Engineering Technology (ECET) department. The program's implementation was two-tiered. In Tier 1, over a period of three years, the WRIT staff presented writing strategies to the ECET faculty: using a course journal; improving writing in the lab report; evaluating writing holistically; and, in the third year, the introduction of the microtheme, which resembles both vocational and English discourse in its several manifestations of summary-writing, thesis-support, data provision, and quandary posing aspect. All strategies were well-received and were implemented, with the exception of the narrative lab report, which met with resistance from the ECET faculty. Together, WRIT staff and ECET faculty developed curriculum materials on WRIT writing strategies for the first two courses required in both the electrical and computer technology programs. In Tier 2, informed about how to think about writing, the ECET faculty themselves, spurred on by their accrediting association, inserted writing into their lab report. In conclusion, this experience indicates that: (1) English teachers can play a role in other disciplines through teaching the value of writing and approaches to assigning it through generic writing-to-learn assignments, like the journal and microtheme; and (2) vocational faculty will themselves proceed to develop writing assignments for their upper level courses that can be considered "discourse centered." (Sample lab assignments with writing questions are included, and 12 references are attached.) (SR)

\*\*\*\*\*  
 \* Reproductions supplied by EDRS are the best that can be made \*  
 \* from the original document. \*  
 \*\*\*\*\*

ED322496

The Best of Both Discourse Worlds: A Two-Tiered Writing Program for the Community College Technology Curriculum

Dr. Linda Stanley  
English Department  
Queensborough Community College  
Bayside, New York 11364.

CS212395

"PERMISSION TO REPRODUCE THIS MATERIAL IN MICROFICHE ONLY HAS BEEN GRANTED BY

*Linda Stanley*

TO THE EDUCATIONAL RESOURCES INFORMATION CENTER (ERIC)."

U.S. DEPARTMENT OF EDUCATION  
Office of Educational Research and Improvement  
EDUCATIONAL RESOURCES INFORMATION CENTER (ERIC)

- This document has been reproduced as received from the person or organization originating it.
- Minor changes have been made to improve reproduction quality.

• Points of view or opinions stated in this document do not necessarily represent official OERI position or policy.

## The Best of Both Discourse Worlds: A Two-Tiered Writing Program for the Community College Technology Curriculum

In Barbara Stout and Joyce Magnotto's essay on (the results) of their survey of community college WAC programs in (Sue McLeod's) Strengthening Programs for Writing Across the Curriculum, they suggest that our WAC program at Queensborough is unusual because we originally concentrated on the technologies (McLeod 24-25). For us in WRIT (Writing and Reading in the Technologies), beginning our WAC work on campus with the technologies was a logical decision. When we received a grant in 1982 from the State of New York Vocational Education Administration, we chose to work with our Electrical and Computer Engineering Technology Department (ECET). Not only is ECET one of the largest and most progressive departments on our campus, but also its chairperson had always been supportive of the efforts of our WAC committee to find funding and an engineer was an enthusiastic member of the committee.

We have never regretted our decision to work with ECET. More than half of the department of 30 full-time faculty attended the workshops we ran the first year, and many remain active and influential in WRIT now eight years later. However, in thinking about Stout and Magnotto's assessment and in co-editing a collection of essays on community college WAC programs (Stanley and Ambron 199. that focus largely on writing in the humanities and social studies, I now realize that WRIT is unusual. And so I have asked myself, "Was

working with ECET so difficult? Have we really accomplished anything for a curriculum whose discourse is quite alien to English teachers?" While I am quite sure the engineers would agree that we have accomplished a lot, in thinking back eight years, I recall that we did have problems that we did not solve at the time. In interviewing some of the technology people for this paper, however, I have found that these problems have largely worked themselves out.

What I want to present here is what I have come to think of as our two-tiered implementation of writing in the technologies. I will discuss Tier I as what we in WRIT did and what our resulting successes and failures were, and Tier II as what the technology faculty themselves have done subsequent to the WRIT workshop phase. In so doing, I hope to provide an approach for those programs interested in working with the technologies.

Tier I - WRIT workshops and curriculum development activities for the ECET Department: successes and failures

The three writing strategies that we presented to the ECET Department in the first two years of our project were the assigning of a course journal, improving writing in the lab report, and evaluating writing holistically (Action and Reaction 1/e). We left it up to the faculty whether they would assign a student-centered journal or a content-centered journal, and some assigned one, some the other, and some a

combination of both. With their assistance, we devised a four-point holistic scale. These two strategies were successful (Emanuel "To Write, Or Not to Write," and Stanley "Writing and Reading in the Technologies"). At the end of the second year, we had a reception for Queensborough ECET faculty and students who were assigning and keeping a journal.

In preparing the workshop on the lab report, we collected samples of different lab reports. We expected to find faculty using the traditional narrative report that includes some combination of the following sections: Object, Theory, Procedure, Apparatus, Data, Sample Calculation, Results, Conclusion, Discussion. We found no examples of this type of lab report at Queensborough.

The type of lab report that we found in common use is referred to by the engineers themselves as the "cookbook" report; ie, it takes students step-by-step through the procedure for writing the report, which consists mainly of calculations, measurements, and the construction of diagrams (see Table 1). The emphasis here is not on the results themselves but on the process by which they are reached. The purpose of writing such a report is to confirm theory and to learn how to work the equipment.

A third type of report in less frequent use included along with the calculations and measurements what we termed "guided questions," which called for short, narrative responses (see Table 2). These questions were very effective

in eliciting reasoned responses. However, the amount of space left on the pre-packaged report for writing did not allow for a substantial answer.

In order to provide students with the opportunity to learn through writing and to elicit from them a substantial enough writing sample to evaluate, we needed to impress upon the engineers the need either a) to use the traditional narrative report format, b) to supplement the cookbook lab report with substantial writing assignments or c) to encourage more writing in the guided question reports.

Having located a narrative lab report from another source, we gave the engineers samples of each type of lab report and asked them three questions:

1. What evidence is there that the student demonstrated proficiency in using the equipment?
2. What evidence is there that the student demonstrated a complete, accurate, and clear understanding of the experiment?
3. What evidence is there that the student learned by doing the experiment?

Most of the participants felt that the guided question report forced the student to do the most thinking about the experiment, but some felt that the narrative report provided a more complete overview of the experiment. One suggestion was that the traditional subdivisions of the narrative report be retained but that guided questions be formulated for each subdivision to encourage the student to understand

why the experiment is important; this combination report would be in lieu of producing narratives that tend simply to summarize the activities and concepts of the experiment.

Another suggestion was to group all narrative answers together or ask one question that would require a substantial response.

The question was moot, however, as the ECET department was not immediately interested in assigning writing in the lab reports. Because this was the least well-attended workshop, they had decided before hand that they did not want to change their approach to the lab report. Their reluctance was for several reasons as we learned later: they believed that for the first semester courses in electrical circuit analysis, students could not handle much more than the calculations themselves. They had written and published the lab manuals and could not easily change the format. Some were uncomfortable with writing and were fond of saying that they were number crunchers, not writers.

In the next year, without further discussion, we worked with the ECET department to develop curriculum materials on WRIT writing strategies for the first two courses required in both the electrical and computer technology programs (Emanuel et al. Writing and Reading Strategies for ET-110). In the third year, we introduced the microtheme to the faculty from the several vocational departments with whom we were now working, and it became an immediate success (Ambron). In its several manifestations--summary-writing,

thesis-support, data-provided, quandary-posing--the microtheme resembles both vocational and English discourse. Further, it calls for a sufficient amount of writing--John Bean defines it as the amount of writing that can be typed on a 3 x 5 card--to involve the students in learning and to make evaluation possible and yet not time-consuming (John Bean et al.). Because we and the vocational faculty were happy with the microtheme, we more or less gave up on the lab report and even dropped it from the second edition of our handbook, Action and Reaction.

Of the journal and microtheme, Joanna Ambron, WRIT coordinator of biology who teaches in our Medical Laboratory Technology Program, says "The journal gets them writing and recording and promotes their intellectual development, while the microtheme is an advancement into disciplinary thinking and actually can be advantageous in the upper level courses." Perry Emanuel, our ECET coordinator, says that the journal is a great boon to retention of subject matter and also is an introduction to on-the-job writing in the form of the engineer's log book. The microtheme, he feels, provides for more learning than the journal but not as much retention as it is written less frequently. He prefers both to the lab report in terms of student learning.

Despite our successes, however, we had not solved the problem of how to insert discourse-centered writing into the ECET curriculum. Martin Spear and Dennis McGrath, two social science teachers from the Community College of Philadelphia



who wrote an essay for our book on WAC in the community college say that we shouldn't have tried to do so--that English teachers have no business trying to teach the writing of other discourse communities because they do not understand the conventions (Spear et al.).

But the engineers had rejected narrative lab reports. A dilemma? Well, no, because Tier II occurred.

Tier II. Informed by WAC about how to think about writing, the engineers, spurred on by their accrediting association, have inserted writing into the lab report.

The first year of our project, 1983, was also the year that the ECET department came up for reaccreditation. The Accreditation Board for Engineering and Technology (ABET) was very supportive of our efforts in WRIT and invited me to speak at an ABET conference in Atlanta. They postponed full accreditation of the ECET program that year until more writing was included in first semester lab reports.

With some grumbling, the engineers set about the following year adding narrative conclusions to their lab reports. By adding the writing in one location at the end of the report, they did not have to alter the reports themselves, although more recently published lab manuals include these narrative conclusions (Table 3). They give WRIT credit for having "raised their consciousness," as they put it, as to how and where to assign writing.

The influence of an accrediting association also encouraged the nursing department at Queensborough to assign in an upper division course a paper that researches and reviews the literature. The assistance of an accrediting association is not a panacea for WAC, however, as many community college vocational programs do not seek accreditation.

Tier II discourse-centered writing has been developed in any case without the nudge of an accrediting association. I have interviewed WRIT faculty from other non-accredited vocational programs and discovered that they too have been influenced by what they have learned about writing from WRIT to create discourse-centered upper-level writing assignments. Joanna Ambron has begun assigning a lab notebook in her histology course in the Medical Laboratory Technology Program. She indicates that a lab notebook is required on the job to document procedures and results but that she never knew a procedure for assigning it in her courses before WRIT. Because of participating in WRIT (as well as in a City University of New York Faculty Development Program in writing across the curriculum and doing doctoral work in WAC), she now can give a rationale to students for keeping the notebook in terms both of their learning of course material and of learning to think in the discipline.

What have we learned then in WRIT that we can pass on?

1. English teachers can play a role in writing in other disciplines through teaching the value of writing and

approaches to assigning it through generic writing-to-learn assignments, like the journal and microtheme.

2. Vocational faculty will themselves proceed to develop writing assignments for their upper level courses that can be considered "discourse centered."

3. A question remains, however. The reluctance of the ECET faculty to move into discourse-centered writing may reflect a similar reluctance among other community college faculty to plunge even second year students into what is, after all, sophisticated thinking and writing.

Spear and McGrath suggest that the community college student must be taught discipline-centered writing if he or she is to have the option of obtaining a four-year degree and entering the professional job market (Spear et al.).

Vocational faculty need to find ways of teaching key critical thinking and problem-solving skills so that students can think through their technical procedures and solve the problems of their subject matter. At Queensborough we are beginning next year a funded-project called CAPSTONES-- Critical Analysis, Problem-Solving, and Teamwork are Occupational Needs of Every Student--so that the thinking and learning that writing encourages will be of as high an order as possible.

Our experience has shown that as both English teachers and technology faculty become more conversant with what each has to bring to learning and writing, the question of how to assign community college vocational students discourse-

centered writing can be more knowledgeably explored.

### References

- Ambron, Joanna. "Writing to Improve Learning in Biology." Journal of College Science Teaching 16 (February 1987): 263-66.
- Bean, John C., Dean Drenk, and F. D. Lee. "Microtheme Strategies for Developing Cognitive Skills." New Directions for Teaching and Learning: Teaching Writing in All Disciplines. Ed. C. W. Griffin. No. 12. San Francisco: Jossey Bass, 1982.
- Boylestad, Robert L., and Gabriel Kousourou. Experiments in Circuits Analysis to Accompany Introductory Circuit Analysis, 5th ed. Columbus: Merrill Publishing Co., 1987.
- Emanuel, Pericles. "To Write, Or Not to Write." (Queensborough Review: A Journal About Writing, 1986.
- Emanuel, Pericles, Sidney Sonsky, and Stuart Asser. Writing and Reading Strategies for ET-110: Electric Circuit Analysis I. Bayside, New York: WRIT Project, 1987.
- McLeod, Susan H., ed. Strengthening Programs for Writing Across the Curriculum. San Francisco: Jossey Bass, 1988.
- Spear, Martin, Dennis McGrath, and Evan Seymour. "Toward a New Paradigm in Writing Across the Curriculum." Writing Across the Curriculum in the Community College: New Directions for Community Colleges. Eds. Linda Stanley and Joanna Ambron. San Francisco: Jossey Bass, 1991.
- Stanley, Linda, and Joanna Ambron, eds. Writing Across the Curriculum in the Community College: New Directions for Community Colleges. San Francisco: Jossey Bass, 1991.
- Stanley, Linda, Harriet Krantz and Sandra Seltzer. Action and Reaction: Writing and Reading in the Technologies. 1st ed. Bayside, New York: WRIT Project, 1983.
- Stanley, Linda, Libby Bay, Carol Russett, and Meralee Silverman. Action and Reaction: Writing and Reading in the Technologies and Other Vocational Curricula. 2nd ed. 1986.
- Stanley, Linda. "Writing and Reading in the Technologies." (Queensborough) Faculty Newsletter February 1984.
- Waintraub, Jack L., Edward Brumgnach. Laboratory Manual to Accompany Electric Circuits for Technologists. St. Paul: West Publishing Co., 1990.

# Methods of Analysis

## OBJECT

*To become familiar with the branch-, mesh-, and nodal-analysis techniques.*

## EQUIPMENT REQUIRED

### Resistors

1—1.2-k $\Omega$

2—2.2-k $\Omega$ , 3.3-k $\Omega$

### Instruments

1—DMM (or VOM)

2\*—dc Power supplies

\*The unavailability of two supplies will simply require that two groups work together.

Waintraub, Jack L., Edward Brumagch.  
Laboratory Manual for Technologists.  
St. Paul: West Publishing Co., 1990.

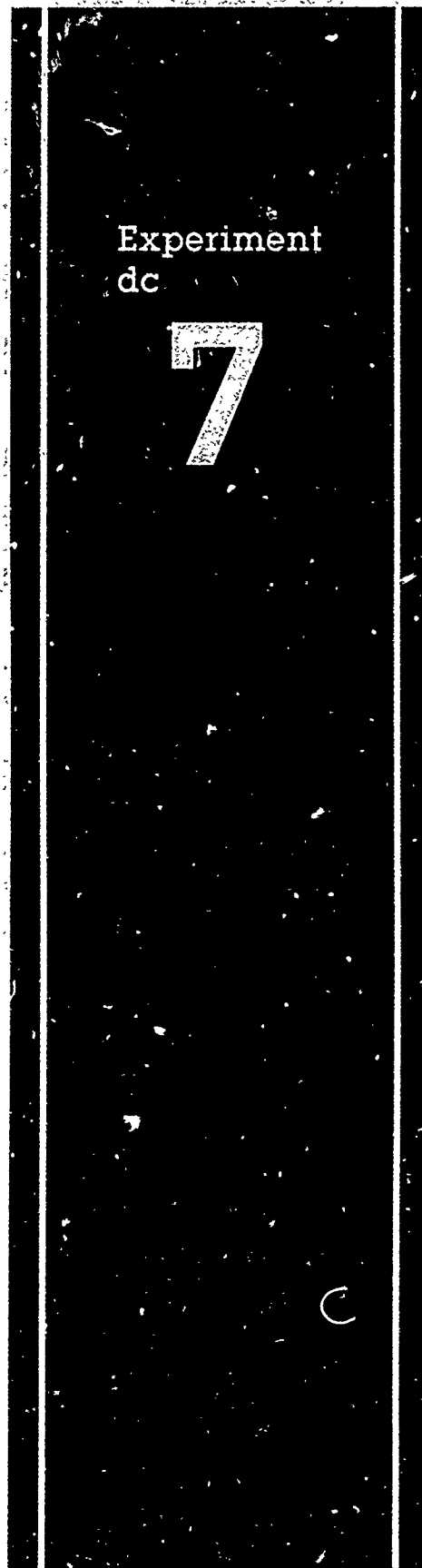

## EQUIPMENT ISSUED

TABLE 7.1

| Item         | Manufacturer and Model No. | Laboratory Serial No. |
|--------------|----------------------------|-----------------------|
| DMM (or VOM) |                            |                       |
| Power supply |                            |                       |
| Power supply |                            |                       |

TABLE 7.2

| Resistors      |                |
|----------------|----------------|
| Nominal Value  | Measured Value |
| 1.2 k $\Omega$ |                |
| 2.2 k $\Omega$ |                |
| 2.2 k $\Omega$ |                |
| 3.3 k $\Omega$ |                |
| 3.3 k $\Omega$ |                |

## RÉSUMÉ OF THEORY

The branch-, mesh-, and nodal-analysis techniques are used to solve complex networks with a single source or networks with more than one source that are not in series or parallel.

The branch- and mesh-analysis techniques will determine the currents of the network, while the nodal-analysis approach will provide the potential levels of the nodes of the network with respect to some reference.

The application of each technique follows a sequence of steps, each of which will result in a set of equations with the desired unknowns. An application of determinants or other mathematical procedures will then provide the results required.

For all percent difference calculations, the equation is

$$\% \text{ Difference} = \frac{|\text{measured} - \text{calculated}|}{\text{calculated}} \times 100\% \quad (7.1)$$

## PROCEDURE

### Part 1

- (a) Construct the network of Fig. 7.1. Insert the measured values of the resistors.

METHODS OF ANALYSIS

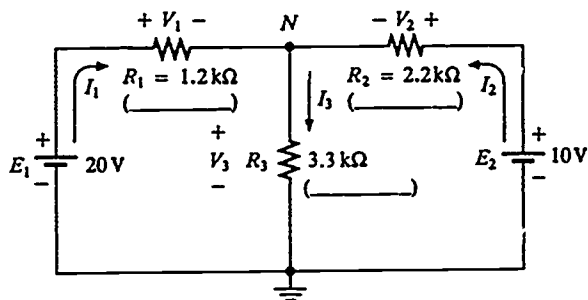

Caution: Be sure dc supplies are hooked up as shown (common ground) before turning the power on.

FIG. 7.1

(b) Using branch-current analysis, calculate the current through each branch of the network of Fig. 7.1 and insert in Table 7.3. Use the measured resistor values and assume the current directions shown in the figure.

TABLE 7.3

| Current | Calculated | Measured | % Difference |
|---------|------------|----------|--------------|
| $I_1$   |            |          |              |
| $I_2$   |            |          |              |
| $I_3$   |            |          |              |

(c) Measure the voltages  $V_1$ ,  $V_2$ , and  $V_3$  and enter below with minus signs if the polarity is opposite to that of Fig. 7.1.

$V_1 = \underline{\hspace{2cm}}$ ,  $V_2 = \underline{\hspace{2cm}}$ ,  $V_3 = \underline{\hspace{2cm}}$

Calculate the currents  $I_1$ ,  $I_2$ , and  $I_3$  and insert in Table 7.3 as the measured values. Be sure to include minus signs in the table if the current direction is opposite

to that appearing in Fig. 7.1. Using Eq. (7.1), calculate the percent difference for each current.

(d) Using nodal analysis, determine the nodal voltage for the network of Fig. 7.1. Use the measured resistor values and be sure to convert each source to a current source before applying the method.

$$V_N = \underline{\hspace{2cm}}$$

(e) Since  $V_N = V_3$ , insert the measured value of  $V_3$  below.

$$V_N = V_3 = \underline{\hspace{2cm}}$$

(f) Calculate the percent difference between the two values.

$$\% \text{ difference} = \underline{\hspace{2cm}}$$

## Part 2

(a) Construct the network of Fig. 7.2. Insert the measured value of each resistor in the diagram.



**METHODS OF ANALYSIS**

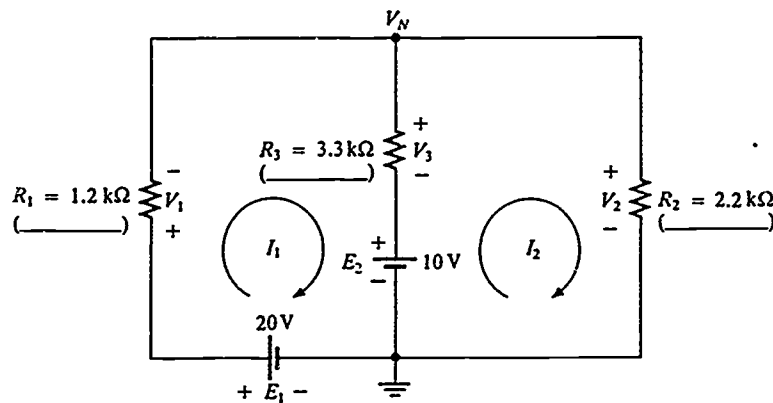

Caution: Be sure dc supplies are hooked up as shown (common ground) before turning the power on.

**FIG. 7.2**

(b) Using mesh analysis, determine the current through each resistor. Use the measured resistor values and the indicated direction for the mesh currents. Insert the calculated resistor currents in Table 7.4.

mesh currents:  $I_1 = \underline{\hspace{2cm}}$ ,  $I_2 = \underline{\hspace{2cm}}$

**TABLE 7.4**

| Current  | Calculated | Measured | % Difference |
|----------|------------|----------|--------------|
| $I_{R1}$ |            |          |              |
| $I_{R2}$ |            |          |              |
| $I_{R3}$ |            |          |              |

(c) Measure the voltages  $V_1$ ,  $V_2$ , and  $V_3$  and enter below with minus signs if the polarity is opposite to that of Fig. 7.2.

$$V_1 = \underline{\hspace{2cm}}, V_2 = \underline{\hspace{2cm}}, V_3 = \underline{\hspace{2cm}}$$

Calculate the currents  $I_{R_1}$ ,  $I_{R_2}$ , and  $I_{R_3}$  and insert in Table 7.4 as measured values. Be sure to include minus signs in the table if the current direction is opposite to that defined by the polarity of the voltage across each resistor. Using Eq. (7.1), calculate the percent difference for each current.

(d) Using nodal analysis, determine the nodal voltage for the network of Fig. 7.2. Use the measured resistor values.

$$V_N = \underline{\hspace{2cm}}$$

(e) Since  $V_N = V_2$ , insert the measured value of  $V_2$  below.

$$V_N = V_2 = \underline{\hspace{2cm}}$$

(f) Calculate the percent difference between the two values.

$$\% \text{ difference} = \underline{\hspace{2cm}}$$

**METHODS OF ANALYSIS**

**Part 3**

(a) Construct the network of Fig. 7.3. Insert the measured resistor values.

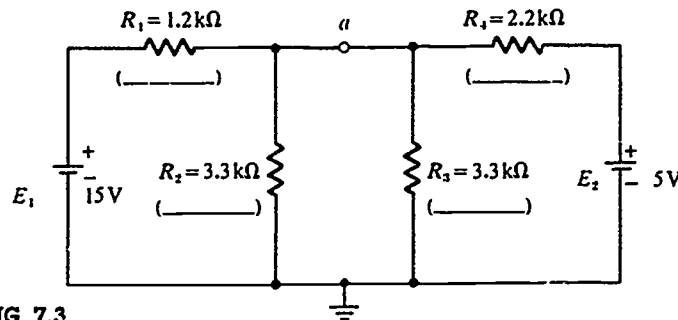

**FIG. 7.3**

*Caution:* Be sure dc supplies are hooked up as shown (common ground) before turning the power on.

(b) Using nodal analysis, calculate the voltage  $V_a$ . Use the measured resistor values.

$V_a$  (calculated) = \_\_\_\_\_

(c) Measure the voltage  $V_a$  and record below.

$V_a$  (measured) = \_\_\_\_\_

(d) Calculate the percent difference between the two values.

% difference = \_\_\_\_\_

**Part 4**

(a) Construct the network of Fig. 7.4. Insert the measured resistor values.

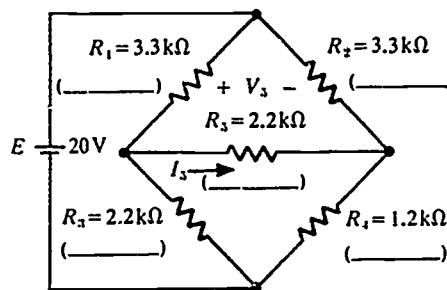

FIG. 7.4

(b) Using any one of the three techniques examined in this experiment, calculate the voltage  $V_5$  and the current  $I_5$ . Use the measured resistor values.

$V_5$  (calculated) = \_\_\_\_\_,  $I_5$  (calculated) = \_\_\_\_\_

(c) Measure the voltage  $V_5$  and insert below with a minus sign if the polarity is different from that appearing in Fig. 7.4.

$V_5$  (measured) = \_\_\_\_\_

(d) Calculate the percent difference between the two values.

% difference = \_\_\_\_\_

**Questions that Can be Used in  
Phrasing Writing Assignments for the Lab Report  
and for Other Writing Assignments**

*Questions Calling for Analysis*

1. Define what is meant by the term . . . ? (*Definition*)
2. What process is involved in . . . ? (*Process Analysis*)
3. Compare X with Y. (*Comparison/Contrast*)
4. Why is X used rather than Y? (*Comparison/Contrast*)
5. What analogy can you draw about the lab? (*Comparison/Contrast*)
6. What is the effect of . . . ? (*Cause/Effect*)
7. What are the sources of error? (*Cause/Effect*)
8. Why is this result obtained? (*Cause/Effect*)
9. What happens to . . . ? (*Cause/Effect*)
10. Do your results confirm . . . ? Explain. (*Reasons why*)
11. Does your data confirm . . . ? Explain. (*Reasons why*)
12. Why must this procedure be followed? (*Reasons why*)
13. Why is this referred to as . . . ? (*Reasons why*)

*Questions Calling for Synthesis*

14. Identify the problem and devise a solution. (*Problem/Solution*)
15. What conclusions can you draw? (*Generalization*)
16. Can you relate this lab to any theory raised in class? (*Generalization*)
17. What is the purpose of . . . ? (*Generalization*)

*Evaluation*

18. Evaluate the data. (*Evaluation*)

Stanley, Linda, Libby Bay, Carol Russett, and Meralee Silverman. *Action and Reaction: Writing and Reading in the Technologies and Other Vocational Curricula*. 2nd ed. 1986.

**Laboratory Experiment 12-****Superposition Theorem and Delta-y, y-Delta Transformation**

(Recommended Time: 1 session)

**Reference**

Waintraub & Brumgnach: Electric Circuit for Technologists West Publishing Co., St. Paul, MN 1989 Pages: 228- 231, 236-240

**Objectives:**

1. To hook up a resistive circuit with more than one supply.
2. To use the Superposition Theorem to solve a multi-source circuit.
3. To solve a resistive network using Delta-y and y-Delta Transformation.

**Equipment:**

1. Resistors: 1k  $\Omega$ , 680  $\Omega$ , 470  $\Omega$ , 330  $\Omega$ , 220  $\Omega$  (1/2 Watt)
2. 2 Variable DC power supplies or 1 Variable DC power supply and a 1.5 volt battery
3. Multimeter (analog or digital)
4. Hook up leads

Boystead, Robert L., and Gabriel Kousurou. Experiements in Circuits Analysis to Accompany Introductory Circuits Analysis, 5th ed, Columbus: Merrill Publishing Co., 1987.

**Procedure**

1. The Superposition Theorem is a method used to analyze multi-source circuits. The Superposition Theorem states that the current through any component or the voltage across any component in a multi-source circuit is equivalent to the algebraic sum of the current or voltages contributed by each individual source.

To analyze a circuit using Superposition, replace all voltage sources except one with a short. Then calculate the voltage and current for each component. Repeat this step for each source in the circuit. Finally add all currents and voltages. Make sure to observe current directions and voltage polarities.

Adjust the DC power supply #1 to 5 volts and DC supply #2 to 1.5 volts. If you don't have a second variable power supply use a 1.5 volt battery.

2. Build the circuit of Figure 12.1.

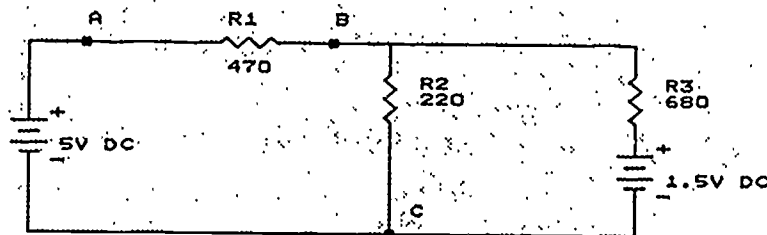

Figure 12.1

3. Using the Superposition Theorem you will solve for the current through and voltage across R2. First measure and record the voltage across and the current through R2. Use a VOM or DMM to make the measurements.

$I_{R2} =$  \_\_\_\_\_

$V_{R2} =$  \_\_\_\_\_







14. Add the two calculated currents from steps 5 and 10. What is the total current?

\_\_\_\_\_

15. Compare the total measured current from step 13 to the total calculated current from step 14. Are they approximately the same?

\_\_\_\_\_

16. Using the calculated total current calculate the voltage across  $R_2$ . What is the calculated voltage?

\_\_\_\_\_

17. Compare the measured voltage from step 3 to the calculated voltage from step 16. Are they approximately the same?

\_\_\_\_\_

18. Compare the total current measured with both supplies connected in step 3 to the calculated current in step 14. Are they approximately the same?

\_\_\_\_\_

20. Turn off both power supplies. Build the circuit of Figure 12.2.

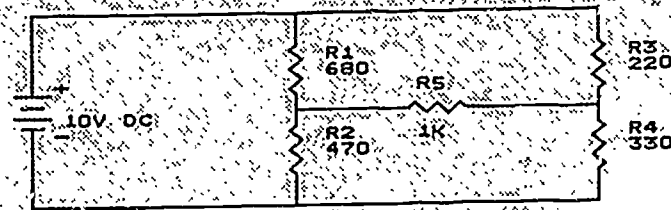

Figure 12.2

21. Measure the total current for the circuit. Then using the delta to y transformation solve for  $R_T$  and calculate the total current. Record your information below.

Measured  $I_T$  = \_\_\_\_\_

Calculated  $I_T$  = \_\_\_\_\_

Measured  $R_T$  = \_\_\_\_\_

Calculated  $R_T$  = \_\_\_\_\_

### Questions

1. What is the Superposition Theorem?
2. How is the Superposition Theorem used to analyze circuits with two or more power supplies?
3. For the Circuit in Figure 12.1, use the Superposition Theorem to solve for the current through and voltage across  $R_3$ .
4. List the steps used to solve a resistive network using the Delta-y, Transformation.

### Discussion

State and discuss any major discrepancies between expected and experimental values. In your own words discuss what you have learned about the Superposition Theorem, the Delta-y and the y-Delta Transformation.